

GRILLES



Philips Arena- Atlanta, Georgia

Built to Last a Lifetime

Cookson rolling grilles are an example of Cookson's uncompromised commitment to quality and value. The grille curtains are still made of 5/16" solid aluminum rods rather than hollow rods used by other manufacturers. The links are 1/8" or 3/16 thick aluminum shapes rather than thinner gauge materials. The links are kept in position by composite tube spacers rather than inexpensive fasteners. The aluminum extruded guides and bottom bars are still made of heavy-walled shapes.

You can buy a cheaper grille, but you can't buy a better grille.

Two Grille Patterns

Cookson offers 2 grille patterns to service a wide range of needs. The standard duty Pattern 5014 is used in most applications where appearance and ease of operation is of utmost importance. When extra security or high cycle use is required Cookson offers the Heavy Duty pattern 5015, where the rods are spaced 33% closer, the links are 50% heavier and there are tube spacers on every rod rather than every 10th rod. Both patterns come standard at 9" vertical link spacing, but 6" and 3" spacing are available at an additional cost.

High Cycle Applications

While most grilles are designed for 20,000 cycles, the Cookson standard grilles are designed for 25 cycles per day and 50,000 life cycles. When higher cycles are required, Cookson manufactures a High Cycle Grille, utilizing either pattern 5014 or 5015, for up to 50 cycles per day and an Ultra-High Cycle Grille, utilizing pattern 5015 for up to 300 cycles per day. Cookson is the High Cycle specialist when it comes to grilles.

Exceptional Finish

The Cookson Company hand made grilles are known for their fit and finish. All Cookson grilles are available in mill, clear anodize and bronze anodize aluminum finishes as well as 2B and #4 polished stainless steel finishes. State of the Art ColorCote (powder coated) finish is also available in 180 standard colors and an unlimited array of custom colors. When finish is a concern, Cookson can provide the solution.



The Cookson Company, Inc.

© 2008

Dimensions shown are for initial design. For final design, specifications, and to view the complete Cookson Product line, visit cooksondoor.com

GRILLES

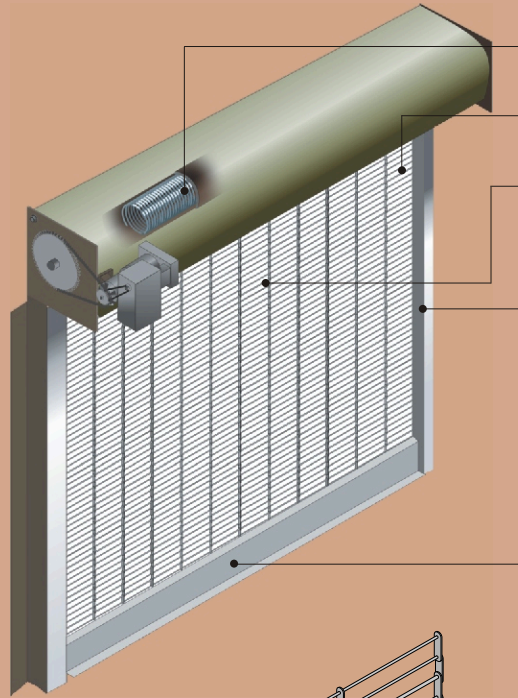

Oil Tempered Torsion Springs Designed for 50,000 Life Cycles

Solid 5/16" Aluminum Rods

Choice of Grille Patterns

Standard (5014) for Grilles to 30'0" Wide
Heavy (5015) for all Size Grilles

Heavy Duty Aluminum Extruded Guides & Bottom Bar

Cycles

Standard 25 per day
High Cycle 50 per day
Ultra High Cycle 300 per day

Choice of Finishes

Mill
Clear & Bronze Anodize
ColorCote in 180 Standard Colors
Stainless Steel 2B and #4 Polish Finish

Choice of Operation

Push-Up - limit 140 square feet or 8' high
Crank
Motor

STANDARD (5014)

5/16" Solid Aluminum Rods spaced 2" apart with 1/2" Diameter Tube Spacers on every 10th rod
1/8" Thick Aluminum Links

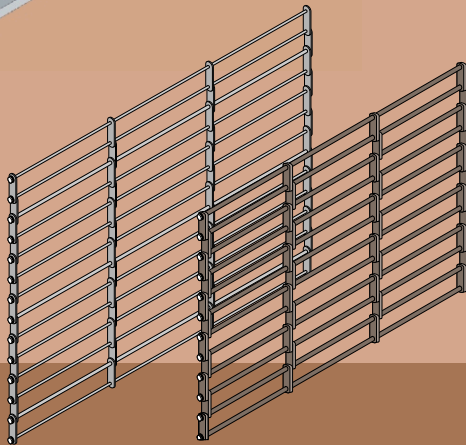

HEAVY (5015)

5/16" Solid Aluminum Rods spaced 1 1/2" apart with 1/2" Diameter Tube Spacers on every rod
3/16" Thick Aluminum Links

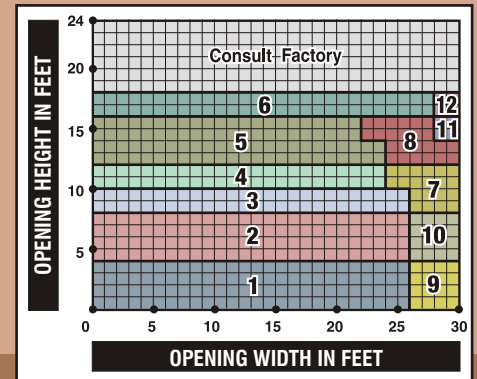

TYPICAL DETAILS

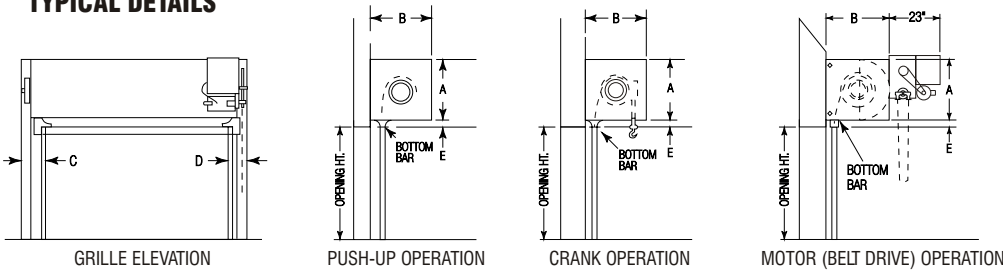

Area	Component Dimensions						
	A	B	C	D	W	X	Y
1	13.0"	14.0"	6.0"	6.0"	2.5"	2.75"	3.5"
2	15.0"	16.0"	6.0"	6.0"	2.5"	2.75"	3.5"
3	16.0"	17.0"	6.0"	6.0"	2.5"	2.75"	3.5"
4	18.0"	19.0"	6.0"	6.0"	2.5"	2.75"	3.5"
5	18.0"	19.0"	6.0"	6.0"	3.0"	2.75"	4.0"
6	20.0"	21.0"	6.0"	8.5"	3.0"	2.75"	5.0"
7	18.0"	19.0"	6.0"	8.5"	2.5"	2.75"	3.5"
8	20.0"	21.0"	6.0"	8.5"	3.0"	2.75"	4.0"
9	15.0"	16.0"	6.0"	8.5"	2.5"	2.75"	3.5"
10	16.0"	17.0"	6.0"	8.5"	2.5"	2.75"	3.5"
11	22.0"	23.0"	6.0"	8.5"	3.0"	2.75"	4.0"
12	22.0"	23.0"	6.0"	8.5"	3.0"	2.75"	5.0"

E= 4 1/2" for manual operation
6" for motor operation with featheredge

