

# WIND-MASTER OPERATIONAL WIND LOAD SERVICE DOOR



## Operational Wind Loads

The Cookson Company introduces a rolling service door that can be operated while under a wind load. Most rolling service doors are designed to withstand a specified wind load when closed but cannot operate under a wind load. The **Wind-Master** Operational Wind Load Service Door can be both opened and closed while being subjected to a 60 MPH wind. Don't let the wind dictate when a door can be used. The Cookson **Wind-Master** Operational Wind Load Door can be used when most rolling doors have to remain in the open or closed position.

## Design Wind Load

The design wind load of a rolling door is "the wind pressure a fully closed door is designed to withstand while remaining intact and safely operable after the wind ceases" as defined in DASMA technical data sheet #279. A rolling door is not normally designed to operate under a wind load, just withstand a wind load.

Under a wind load a standard rolling door is designed to deflect or bend, causing friction between the door curtain and door guide (track). This friction can prevent a door from moving vertically up or down. The wider the door the more it will deflect making many rolling doors inoperable even in light to mild winds. The Cookson **Wind-Master** Operational Wind Load Service Door, with its unique design, will operate in all wind conditions not exceeding 60 MPH.

## Unique Windlock Design

Most rolling doors utilize a curtain mounted windlock to engage the guide mounted windlock bar in order to retain the curtain in the guide when the door is subjected to a wind load. The engagement of the windlock and windlock bar creates extreme friction when a door is operated under a wind load. The Cookson Company has designed a unique Roller Windlock to reduce the friction between the windlock and windlock bar allowing the door to operate under a wind load pressure. Heavy duty ball bearing rollers are used to allow the curtain to freely move up or down while subjected to wind pressure. The door will operate normally even when subjected to a heavy wind load.

## Available as a Standard or Insulated Door

The **Wind-Master** Operational Wind Load Service Door is available as a standard exterior service door or an insulated exterior service door. Either door offers the same Cookson commitment to quality and durability. All **Wind-Master** doors are custom made to exact specifications and include Cookson standards such as a 50,000 life cycle design and a 2 year warranty.

## Tested by an Independent Testing Laboratory

The **Wind-Master** Operational Wind Load Service Door was tested to operate while subjected to a 60 MPH wind load by a nationally recognized independent laboratory. Rather than relying on internally generated engineering calculations, the **Wind-Master** is backed by actual test results. (Test results available upon request.)



Dimensions shown are for initial design. For final design, specifications, and to view the complete Cookson Product line, visit [cooksondoor.com](http://cooksondoor.com)

# THE PREFERRED

## OPERATIONAL WIND LOAD DOOR

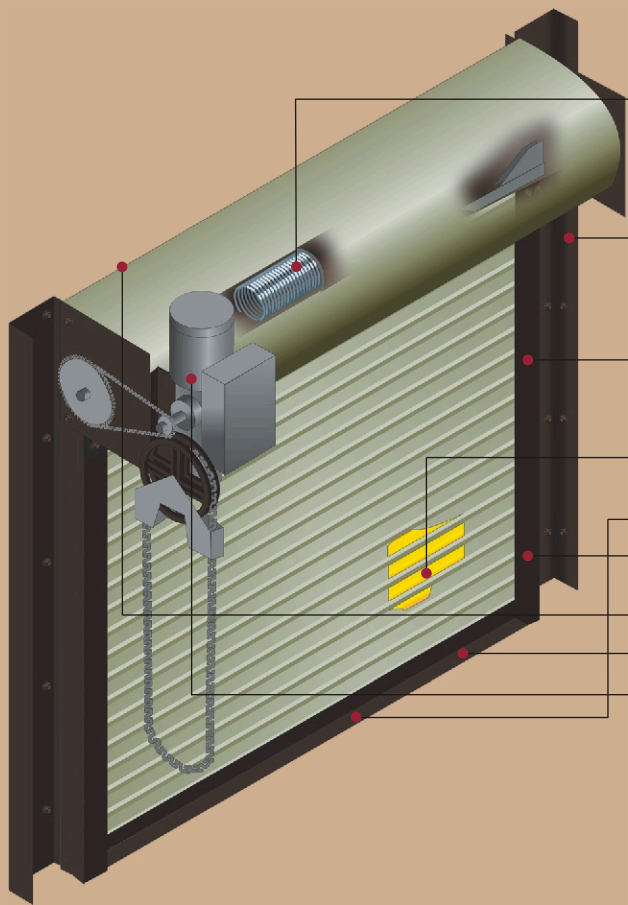

- Oil tempered torsion springs designed for 50,000 life cycles
  - Structural angle guides and bottom bar make door less vulnerable to damage that could prevent the door from operating.
  - Unique roller windlocks to allow the door to operate while being subjected to a wind load.
  - Available in sizes up to 26' 0" wide and 24' 0" high.
  - Insulated Door option includes:
    - Exclusive interlocking slats provide energy efficiency and a finished appearance inside and out.
    - Solid Insulation is inserted between galvanized steel slats to ensure consistent density and complete insulation coverage providing an R value of 4.6.
    - The bottom of the door is sealed by a flexible astragal.
    - Heavy duty vinyl extrusions snap into the guides to reduce dust and air infiltration and to weatherstrip the door jamba.
    - Air seepage around the hood is minimized by a water resistant hood baffle that maintains flexibility in cold temperatures.
  - Heavy duty Gearhead motor operator
- FinalCote Finish Standard
- Available in 180 standard ColorCote Colors (Optional)



**Tested to Operate under Wind Load**

